



POLYKEG PRO WITHOUT BAG
Filling instructions with
PolyKeg[®] manual kit



POLYKEG PRO WITH BAG

Filling instructions with PolyKeg® manual kit

Before filling, please refer to the warnings in the "Section 1" of the PolyKeg PRO instruction manual and to the keg technical data sheets.

- 1 Gas tube
- 2 Pressure top-up connection
- 3 Pressure top-up gauge
- 4 Pressure gauge
- 5 Gas regulator connection
- 6 Counter-pressure regulator
- 7 Product tube
- 8 Product filling connection
- 9 Product filling valve
- 10 Keg coupler (Micro Matic is recommended)

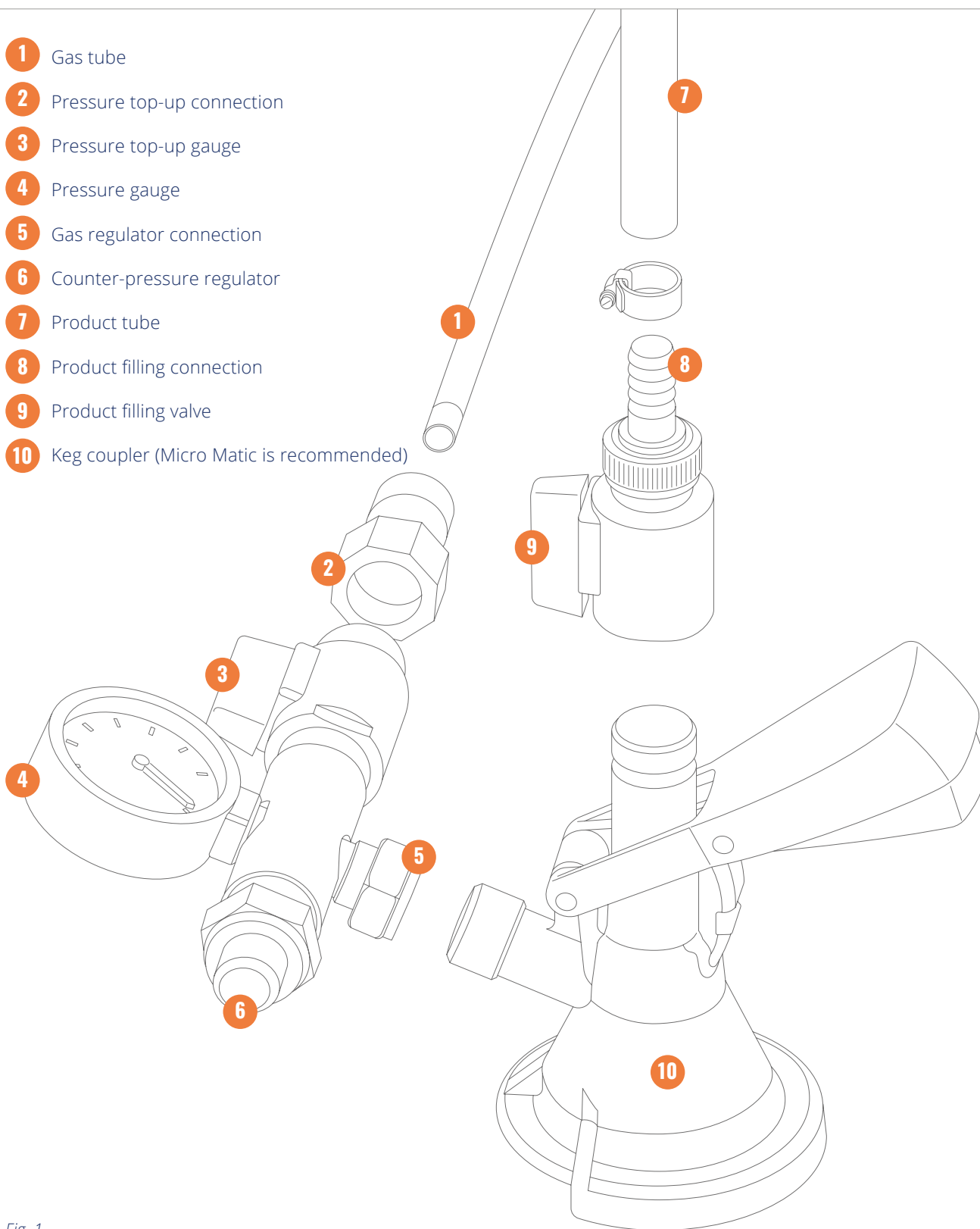

Fig. 1



POLYKEG PRO WITHOUT BAG

Filling instructions with PolyKeg® manual kit

PREPARATION

1. Sanitizing



Disassemble the PolyKeg® filling kit and sanitize the components shown in the picture, following the sanitizing instructions found in "Section 5".

2. Assembly

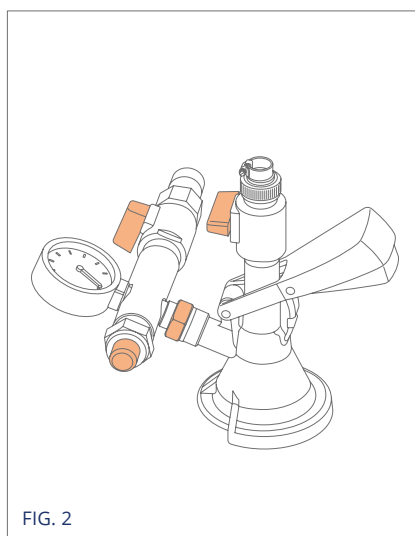

Reassemble the kit properly and close all valves.

3. Gas and product pressure check

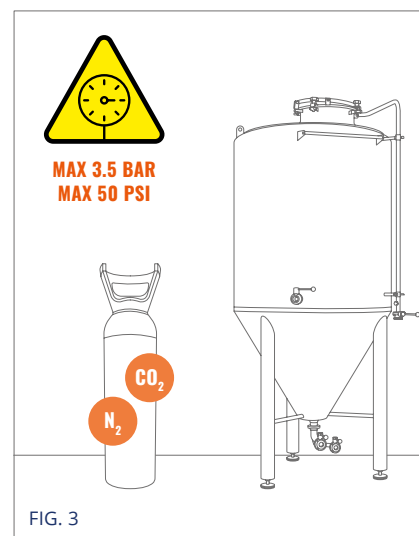

Check that both product and gas pressure in the tank does not exceed the maximum nominal working pressure (3.5 bar).

4. Gas and product tubes connection

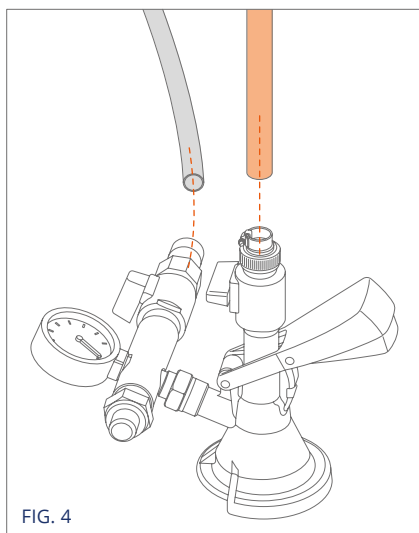

Connect the product and gas tubes to the filling kit.

5. Gas and product tubes connection with K valve

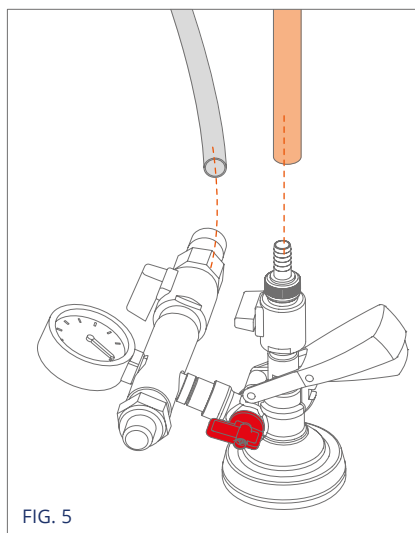

K VALVE ONLY
Connect the product and gas tubes to the filling kit. Open the red valve.

6. Product tube bleeding

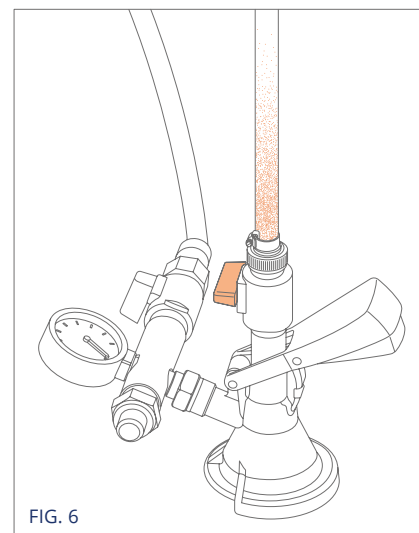

Work with the product valve to remove any residual gas from the product tube. Close the product valve.



FILLING

7. Sanitizing

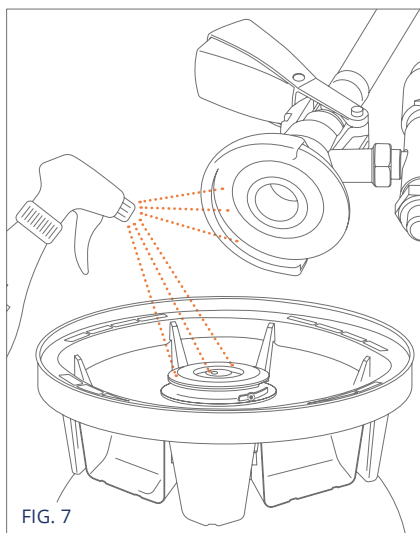

Before filling, sanitize the parts in contact with the product according to the "Sanitizing Instructions" section.

8. Filling head connection and counter-pressure check

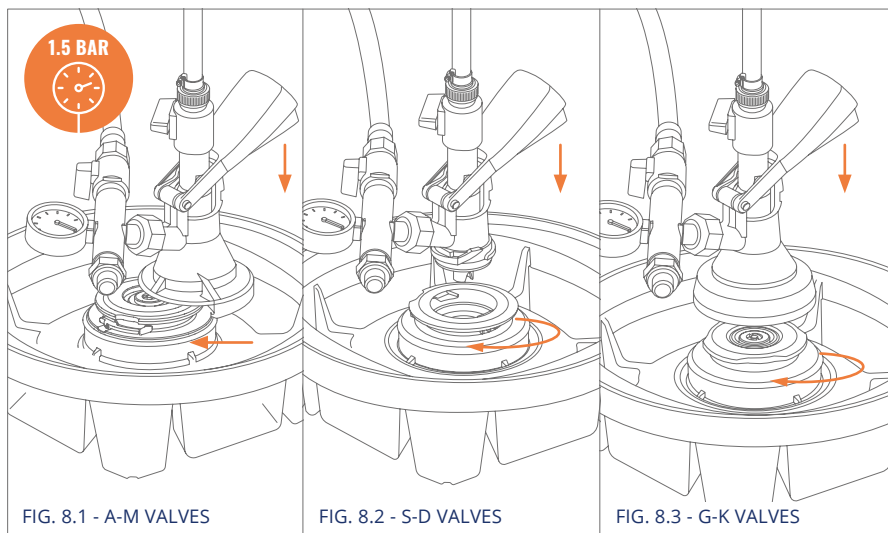

Connect properly the filling head to the valve, lower the lever and check the internal keg pressure.

9. Counter-pressure regulation

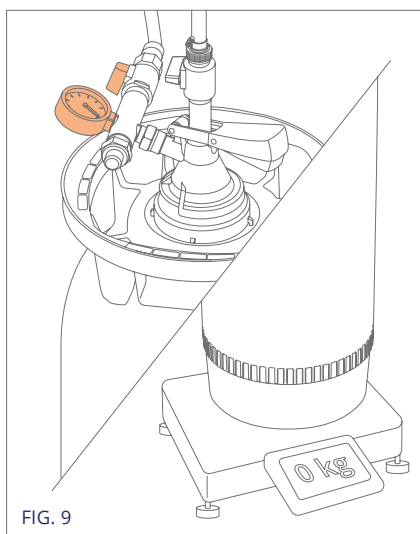

Work with the gas valve until the desired counter-pressure is reached (approx. 0.5 bar lower than the product filling pressure).

10. Filling

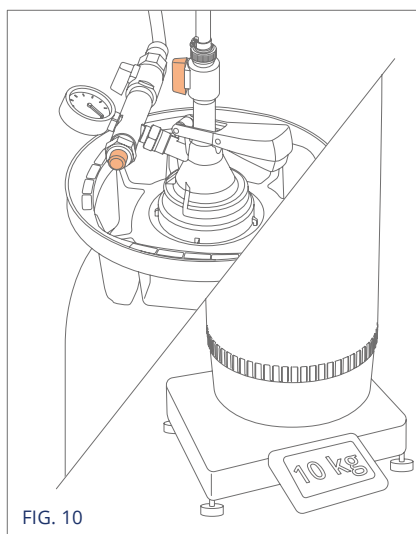

Open the product valve to start filling and work with the counterpressure regulator to set and/or change the filling speed.

11. End of filling

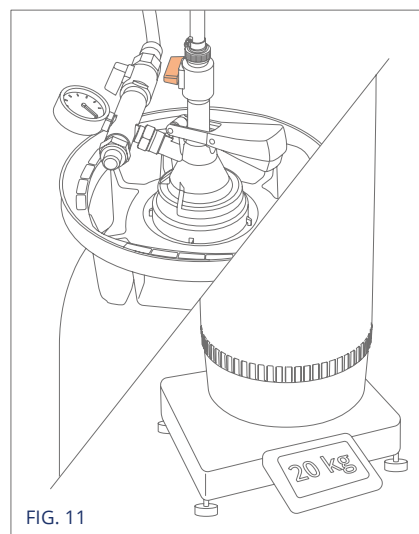

Once the nominal filling volume is reached, close the product valve. Do not exceed the nominal filling volume to prevent the product from leaking.



POLYKEG PRO WITHOUT BAG

Filling instructions with PolyKeg® manual kit

12. Uncoupling

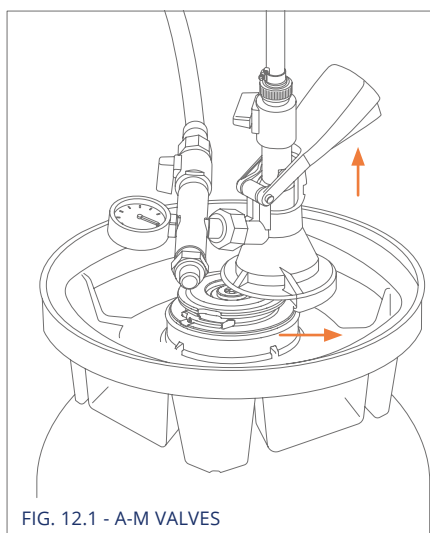

FIG. 12.1 - A-M VALVES

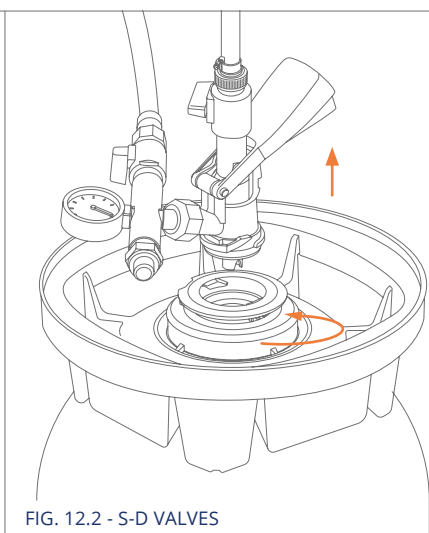

FIG. 12.2 - S-D VALVES

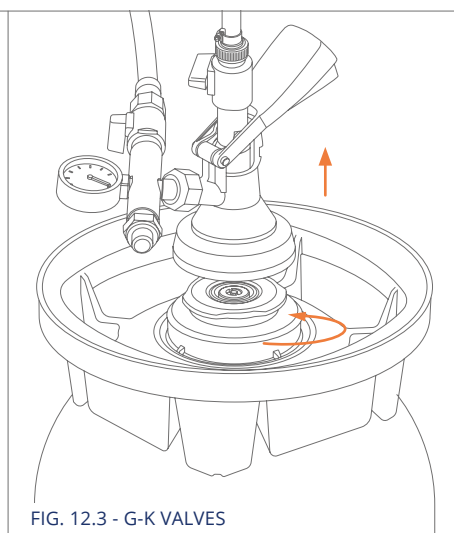

FIG. 12.3 - G-K VALVES

Quickly lift the lever and disconnect the coupler from the keg.

13. Valve sanitizing

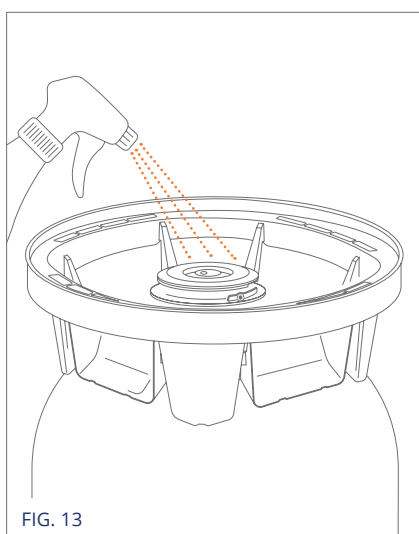

FIG. 13

Remove any residual product with water, sanitize the external part of the valve as per the "Sanitization instructions" section and dry same.

14. Seal Application

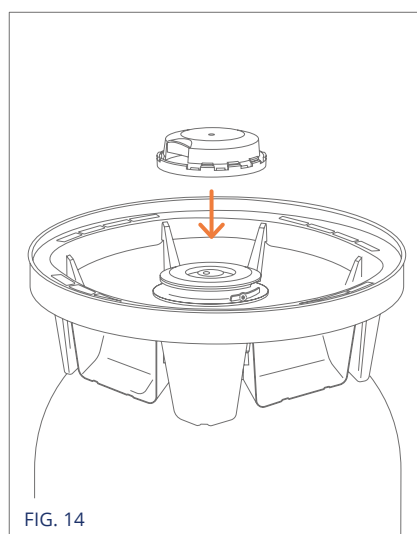

FIG. 14

Apply the keg seal.